

Modular Benchtop Imaging

PET/SPECT/CT



MOLECUBES

www.molecubes.com





At MOLECUBES, we believe that molecular imaging should be accessible to every research lab. It is therefore our mission to lower the barrier to preclinical PET, SPECT and CT imaging by providing compact, intuitive, flexible benchtop imaging solutions with the highest performance, supported by fast and simple workflows. With more than 100 CUBES installed worldwide, MOLECUBES is a trusted partner by your side.



BUILD & SCALE





PET, SPECT, CT standalone

Single modality with 1 CUBE



PET/CT

SPECT/CT

Dual modality with 2 CUBES



PET/SPECT/CT

PET/PET/CT

PET/CT/CT

SPECT/CT/CT

Tri-modality with 3 or more CUBES





Work



flow

CUBEFLOW is designed to maximize your lab's productivity



Step 01

Quality Control

System performance is monitored on-site and remotely

Stable imaging requires stable systems. Automated daily, monthly and periodic quality control procedures are implemented for all CUBES and end-users are trained in implementing them. Dedicated phantoms are provided to make this easy. As scanner fall-out can greatly affect study continuity, ensuring uptime is crucial and is a key focus of our global service teams. Apart from the inherent quality control procedures, our unique system modularity reduces any negative impact caused by scanner failure, as any image modality can operate totally independently from another.

Overall scan uptime is quantified at over 98% on all systems in the market over the last 5 years. MOLECUBES is continuously improving its quality procedures to serve you.

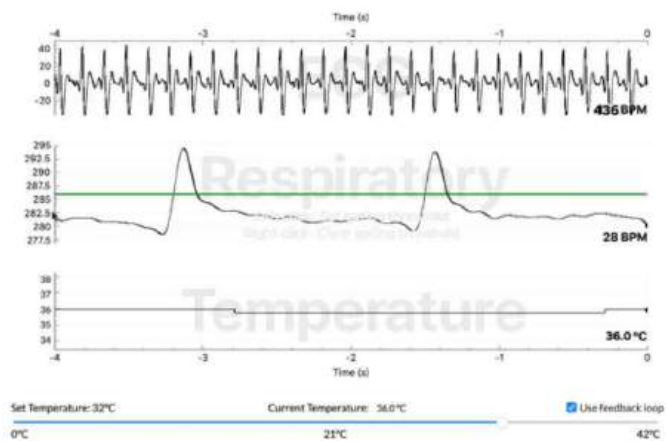
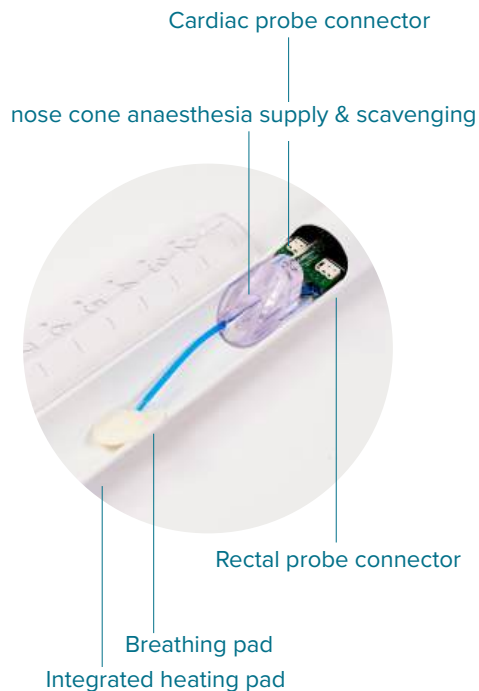

Step 02

Animal Preparation

Animal Preparation stage & Physiological monitoring

MOLECUBES developed a user-friendly small-animal handling and monitoring solution consisting of an integrated preparation stage and a series of animal beds. The stage can be put next to the scanner and is coupled to the anesthetic flow and physiological monitoring. Its ergonomic design facilitates the preparation of both rats and mice, including catheter insertion, tail vein injections and subcutaneous injections.

In order to obtain quantifiable data, keeping the animal's vital signs stable is as crucial as is image quality. Respiratory monitoring can be achieved by means of a respiration pressure pad placed under the chest of the animal. Cardiac monitoring is achieved via three adhesive electrodes attached to a hind limb and the fore limbs. Lastly, temperature monitoring is achieved using a carbon heating pad that does not show any artifacts on CT. The power of the heating pad can be set to achieve a pre-set animal temperature and is maintained through controlled feedback via a rectal probe.

Step 02

Animal Preparation



MOUSE BED

Up to 35g



RAT BED

Up to 350g



RAT XL BED

Up to 450g



MOUSE HOTEL

Up to 4 x 35g

Animal Beds

The MOLECUBES beds allow the user to scan one, two, three or four mice in both PET and CT, and up to 3 mice in SPECT. Individual rats, hamsters or small ferrets can also be scanned in the larger beds. All beds are designed and produced in-house, using durable components that are easy to clean and disinfect. If your lab is equipped with imaging modalities that are complementary to the ones MOLECUBES offers, we will also investigate cross-platform bed compatibility.



Download
The mouse hotel whitepaper

Step 03

Scanning & Reconstruction



Intuitive software interface

In contrast to mainstream approaches, a choice of modular systems inherently facilitates synchronous scanning. Since the modalities are separated into different units, one modality does not block another during the scanning process, as is the case with single gantry systems. When a multi-animal bed can be used in addition, the number of animals scanned within a fixed time frame is further optimized. In addition, our high sensitivity systems reduce scan times significantly, even at low injected doses. This leads to a possible throughput of up to 50 mice per day on a single PET/CT setup.

Step 04

Data management

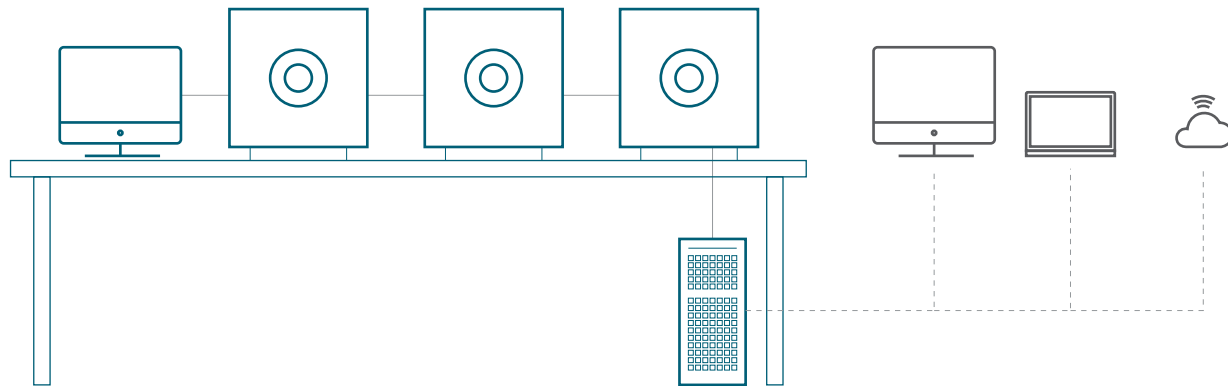

REMI: Reconstruction Engine for Molecular Imaging

Imaging entails a lot more than just selecting the right scanner for the job. Compatibility with data management or preclinical PACS systems is an important driver in reproducible and productive preclinical imaging operations, especially for large cohort studies. Our REMI workstation fulfills exactly these needs when connected to CUBEFLOW. Reconstruction capabilities permit the simultaneous reconstruction of multiple datasets with automated data offloading made possible by an extensive storage capacity. In addition, users are able to set up batch reconstruction protocols for large studies requiring an extensive number of reconstructions with similar parameters. Finally, our CUBEFLOW study planner and data management back-end permit web-based server access from any terminal with network access to the workstation as well as making possible a connection to your preclinical PACS-systems, if available.



Download
White paper REMI

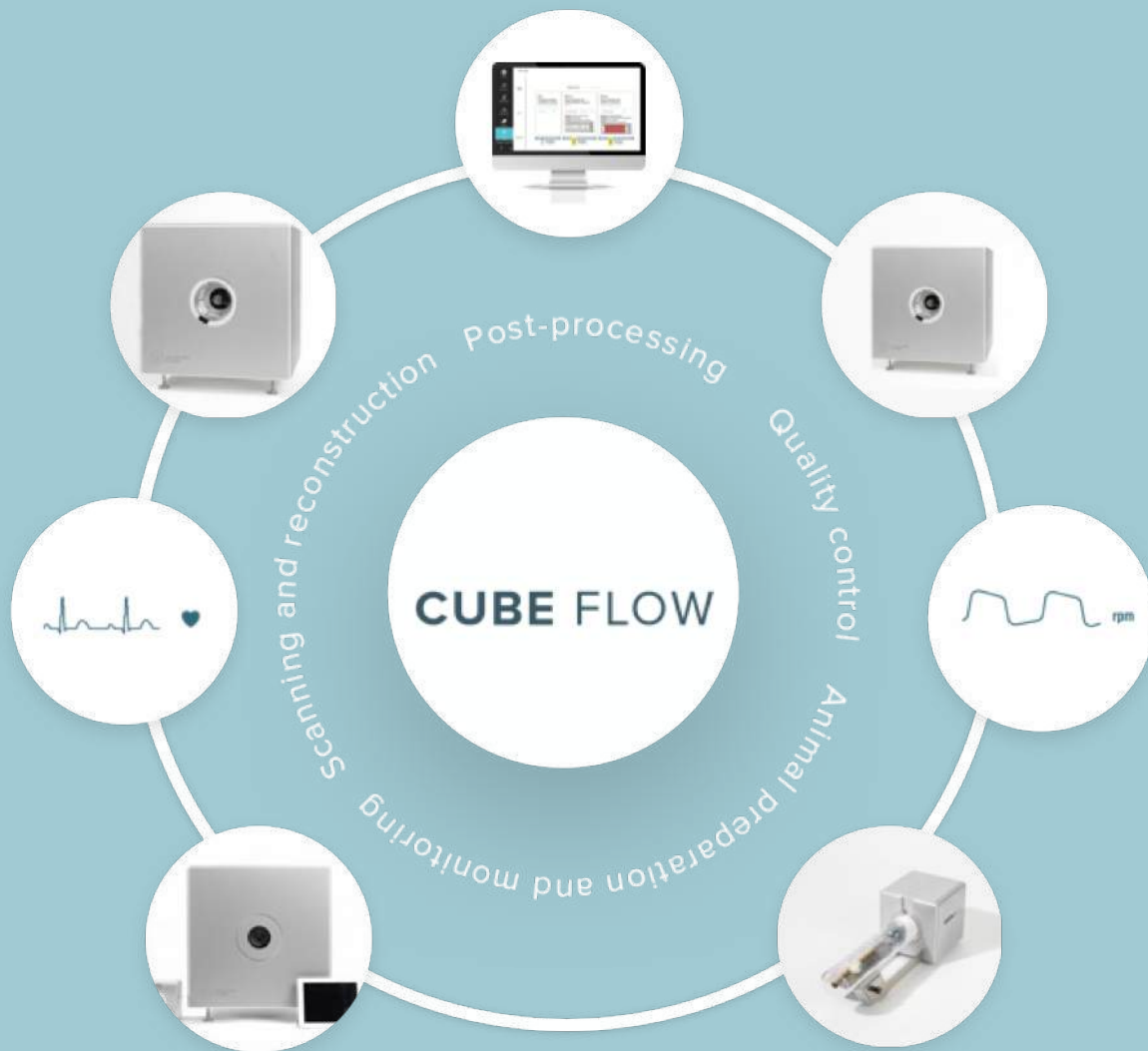

System

tems

PET

β -CUBE

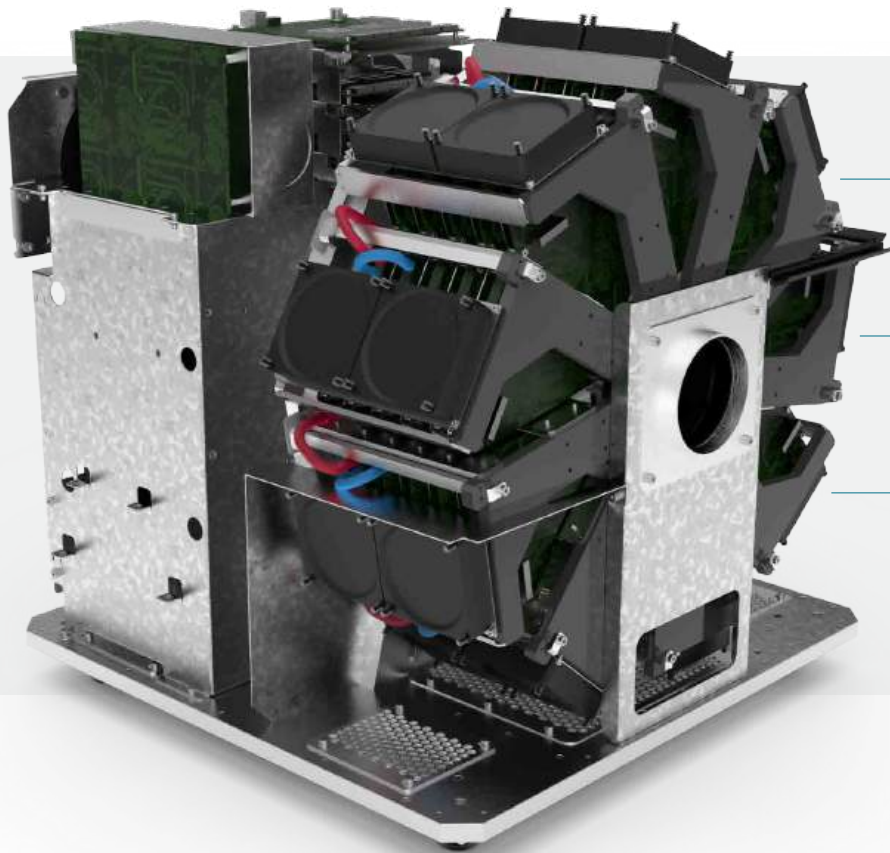

SiPM-based detectors

Active temperature control

Onboard GPU reconstruction

β-CUBE

The β-CUBE is our high-performance preclinical PET imager.

Sub-millimeter image resolution is achieved through the combination of monolithic scintillators, the latest photon counting technology and GPU-based event positioning and iterative image reconstruction. The 5-ring configuration ensures best-in-class sensitivity over a field-of-view adequate for whole-body mouse and rat imaging at high count rate. In-house developed hardware allows for dynamic and gated studies. Intuitive and wireless acquisition software combined with our multimodal small animal bed allow for easy and modular multimodal imaging along with the γ-CUBE (SPECT) and X-CUBE (CT).

Specs

Footprint	540 x 540 x 540 mm
Weight	90 kg
Axial FOV (mouse/rat)	130 mm
Transaxial FOV (mouse/rat)	72 mm
Image Resolution	< 850μm
Peak Sensitivity	> 12 %
Energy Resolution	12.60 %
Crystal/Detector Technology	LYSO cont./SiPM
Reconstruction Algorithms	3D OSEM



β -CUBE

IN-VIVO SCANS

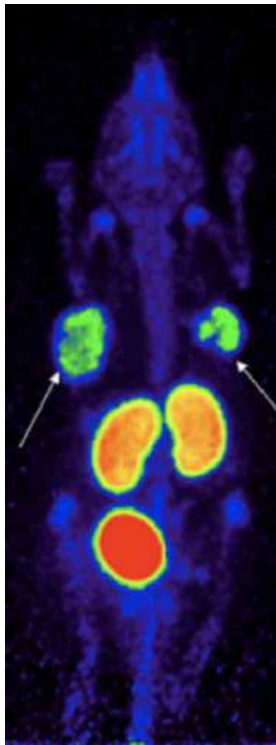

①

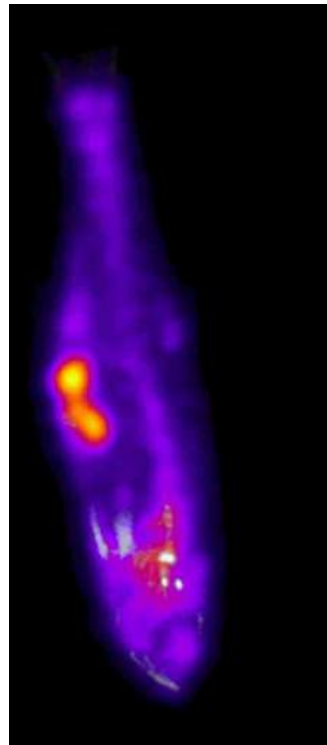

②

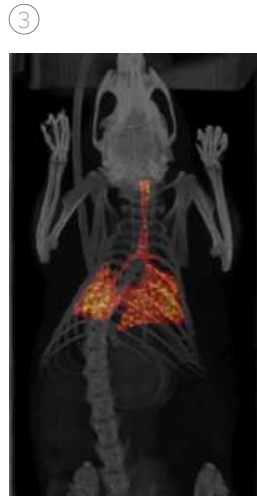

③

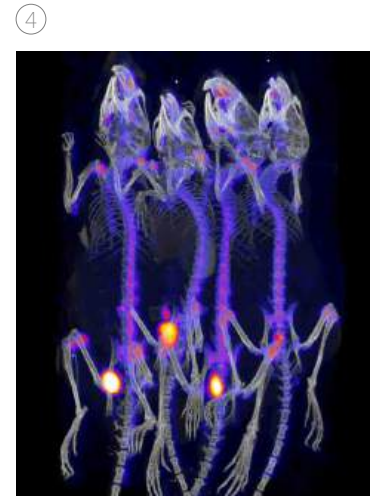

④



⑤

① ^{18}F -PSMA-11 in prostate cancer xenograft
Courtesy of Piron et al., Ghent University

② ^{18}F -NaF in zebrafish

③ ^{18}F -C4F lung imaging
Courtesy of Cossio et al., BIOMAGUNE

④ ^{18}F -NaF mouse hotel

⑤ ^{18}F -FDG mouse brain

⑥ ^{18}F -FDG RAT in rat model of breast cancer metastasis
Courtesy of De Meulenaere et al., Ghent University

⑦ ^{18}F -NaF - MIP rat

⑧ ^{18}F -FCA mouse
Courtesy of De Lombaerde S et al., Ghent University

⑨ ^{18}F -FDG in rat model with glioblastoma

⑥

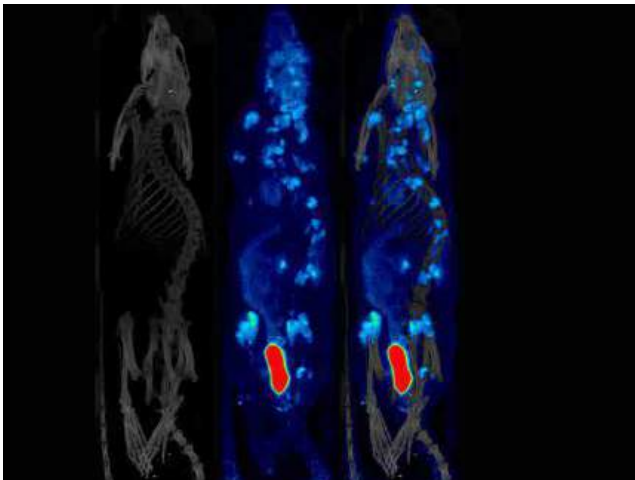

⑧

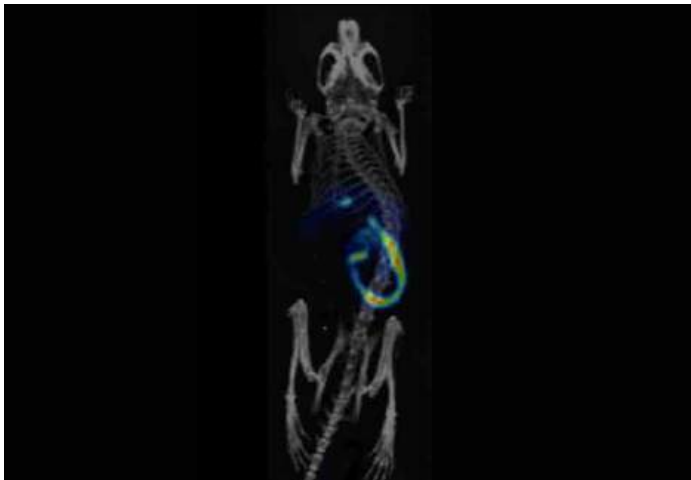

⑦



⑨

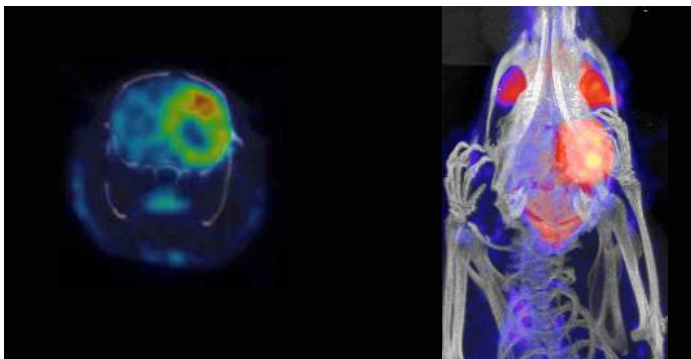

CT

X-CUBE

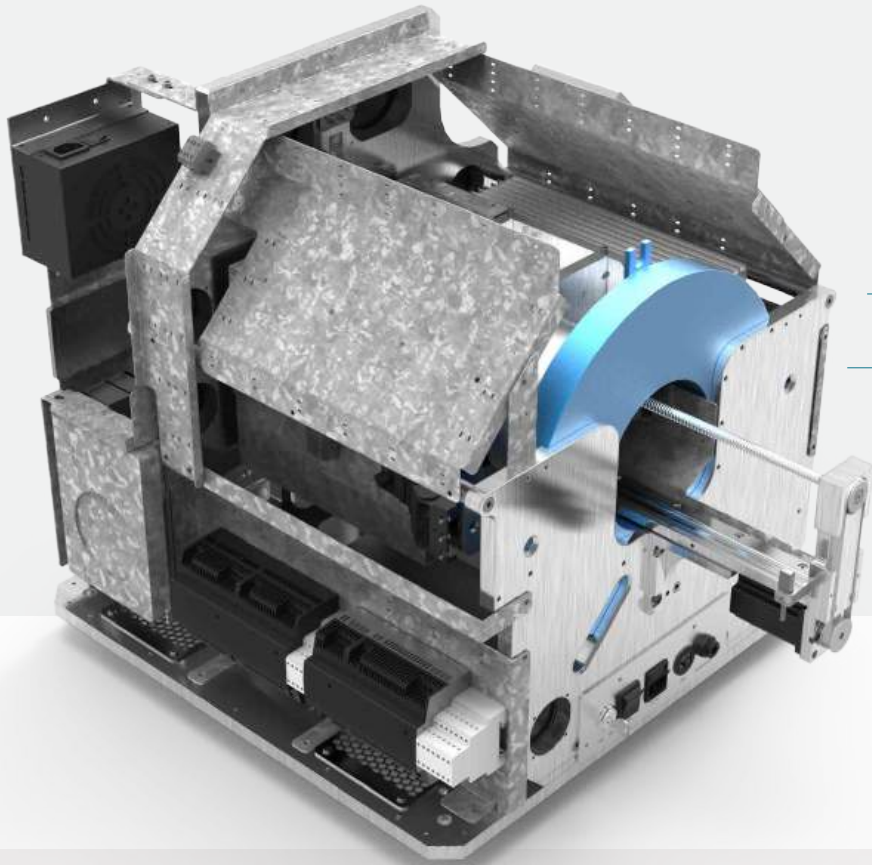

Helical sub-minute acquisition

High-resolution X-ray detector

Microfocus X-ray source

X-CUBE

The X-CUBE is our high throughput CT “work horse”.

It allows for fast whole body mouse and rat CT imaging at extremely low dose and excellent soft tissue contrast. Light weighted thanks to a self-shielded imaging unit it is a truly mobile in vivo scanner. Advanced workflows such as gated and dynamic contrast enhanced imaging can be achieved in a functional and integrated set up. Our iterative reconstruction techniques are available in standard as well as expert user mode. Intuitive and wireless acquisition software combined with our multimodal small animal bed allow for easy and modular multimodal imaging along with the γ -CUBE (SPECT) and β -CUBE (PET).

Specs

Footprint	564 x 540 x 540 mm
Weight	120 kg
Axial FOV (mouse/rat)	37 mm / 1 bed position
Transaxial FOV (mouse/rat)	65 mm
Image resolution	50 μ m
Scan mode	Circular or helical
Energy Resolution	-
Crystal/Detector Technology	14 bit CMOS, 75 μ m
Reconstruction Algorithms	FDK, ISRA
Minimum dose	< 4 mGy

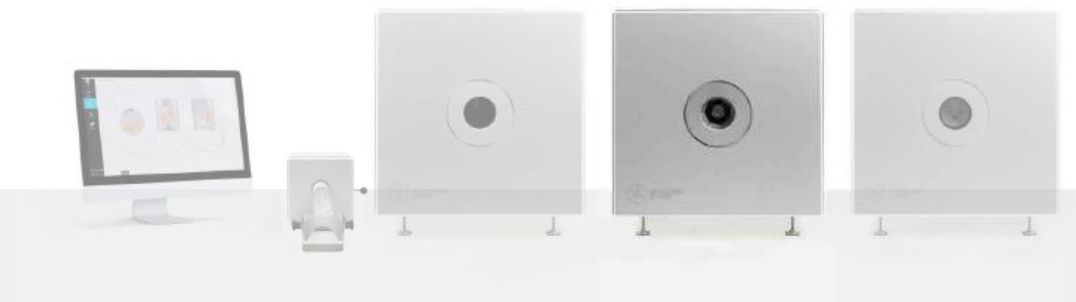

X-CUBE IN-VIVO SCANS

①

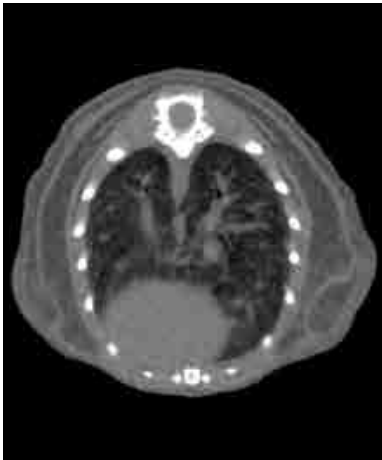

②



③

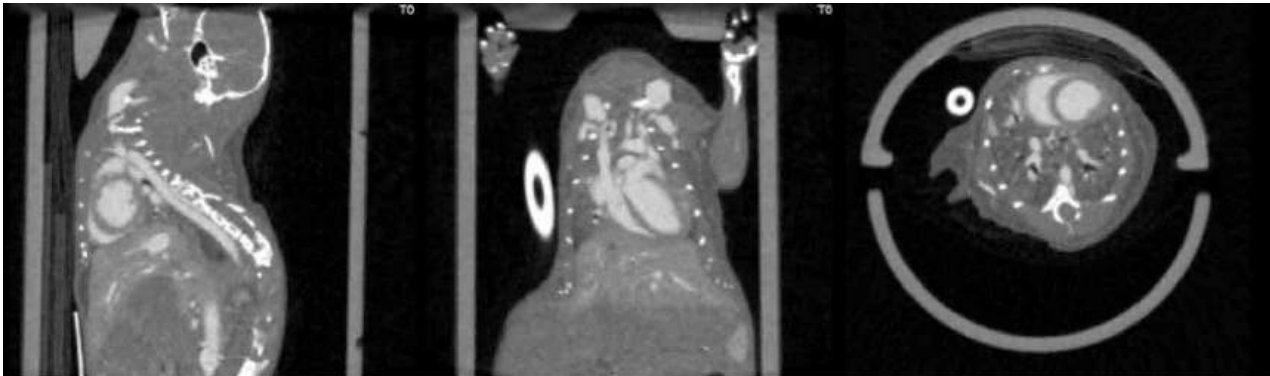

④

- ① Respiratory gated lung imaging.
- ② Visipaque kidney imaging - general purpose protocol.
- ③ Mouse femur - high resolution protocol
- ④ Cardiac gated imaging with Exitron12000

①

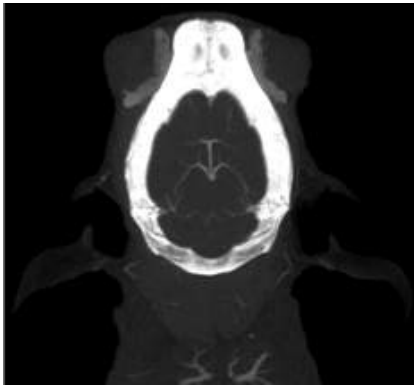
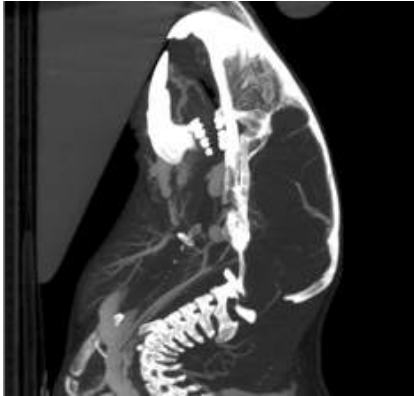

②



③

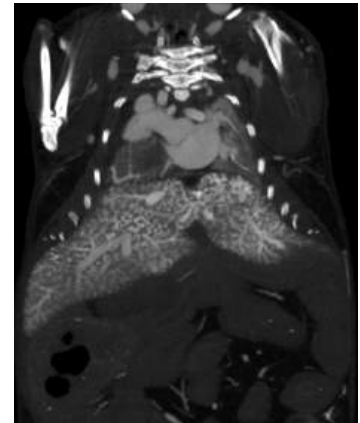

④

⑤

① ③ ④ ⑤

Contrast enhanced CT. Blood vessel imaging with Exitron 12000. High resolution protocol.

②

Bowel imaging with Telebrix gastro. General purpose protocol.

SPECT

Y-CUBE

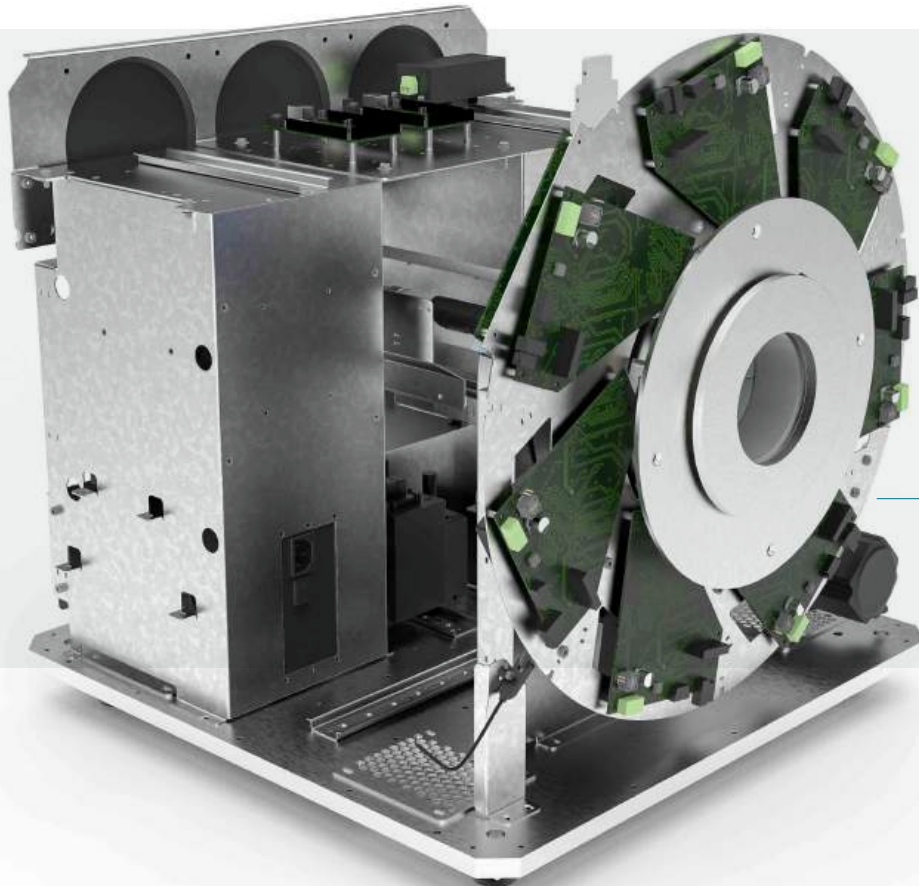

High-resolution scintillation detectors

Onboard image reconstruction

High-precision sintered lofthole collimators

Y-CUBE

The γ -CUBE is our high-sensitivity, high-resolution SPECT imager allowing whole-body mouse and rat imaging. Patented lofthole technology and laser sintered collimators combined with high-resolution detectors result in a high-end true benchtop imager. In-house developed image reconstruction software guarantees fast imaging and excellent image quality. All common SPECT-labelled therapeutic and diagnostic imaging tracers can be imaged. Intuitive and wireless acquisition software combined with our multimodal small animal bed allow for easy and modular multimodal imaging along with the X-CUBE (CT) and β -CUBE (PET).

Specs

Footprint	540 x 540 x 540 mm
Weight	81.5 kg
Axial FOV	Up to 240 mm
Transaxial FOV	up to 60mm
Image resolution	<500 μ m
Peak Sensitivity	1.2%
Energy Resolution	< 11 %
Crystal/Detector Technology	NaI cont./SiPM
Reconstruction Algorithms	3D MLEM
Collimators	general purpose mouse collimator, general purpose rat collimator, high sensitivity collimator

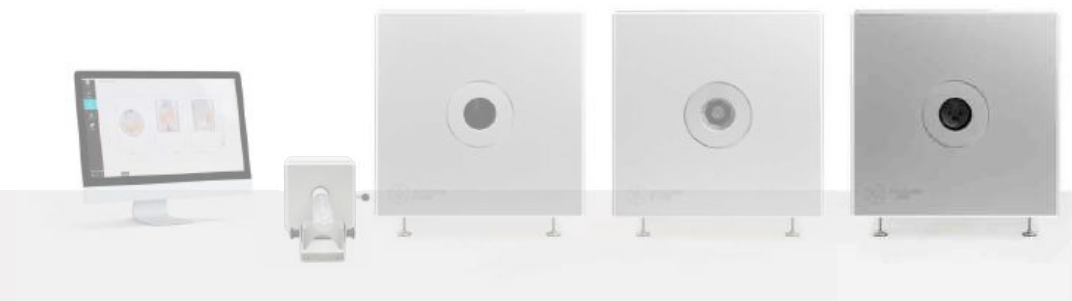

Y-CUBE

IN-VIVO SCANS

①

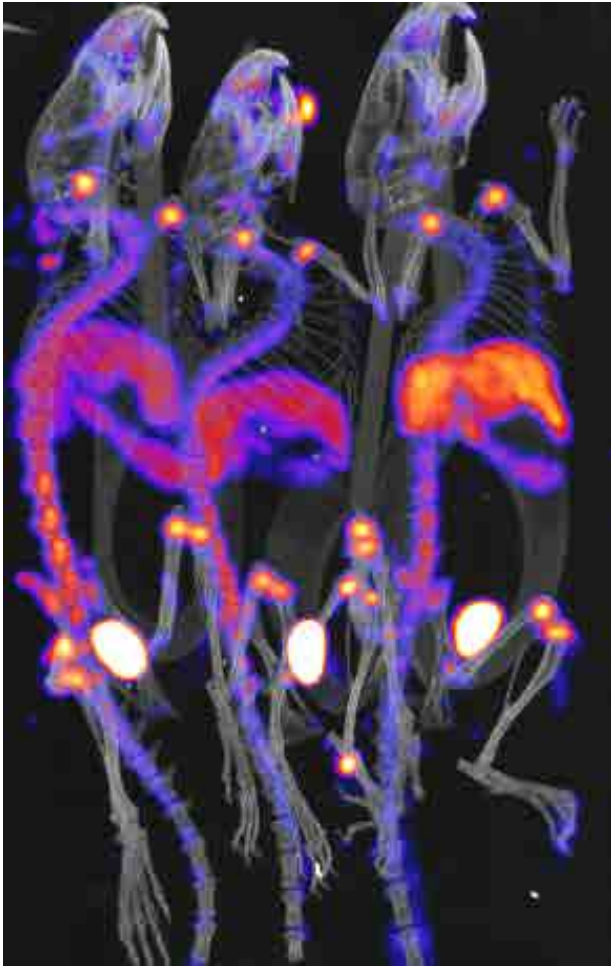

②



③

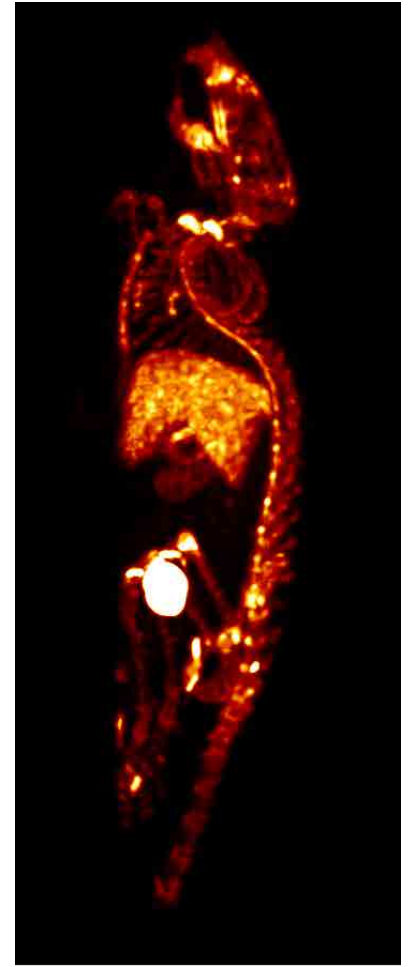

① ^{99m}Tc -HDP SPECT mouse hotel

② ^{99m}Tc -HDP rat

③ ^{99m}Tc -HDP mouse

④ ^{99m}Tc -DMSA rat

⑤ ^{123}I thyroid mouse

⑥ ^{99m}Tc -peptide in mouse xenograft.
Courtesy of Rouchota et al., BIOEMTECH

④

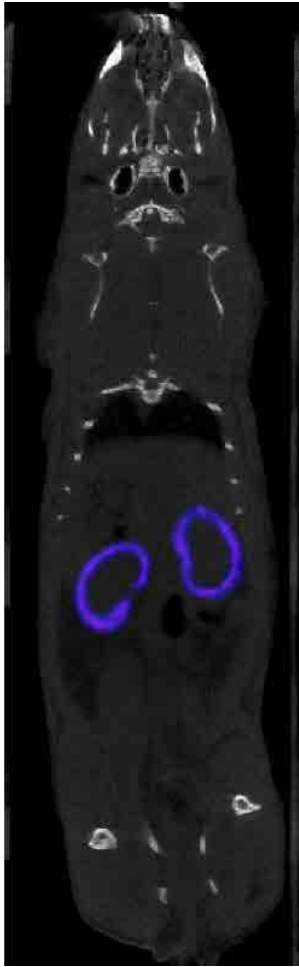

⑤

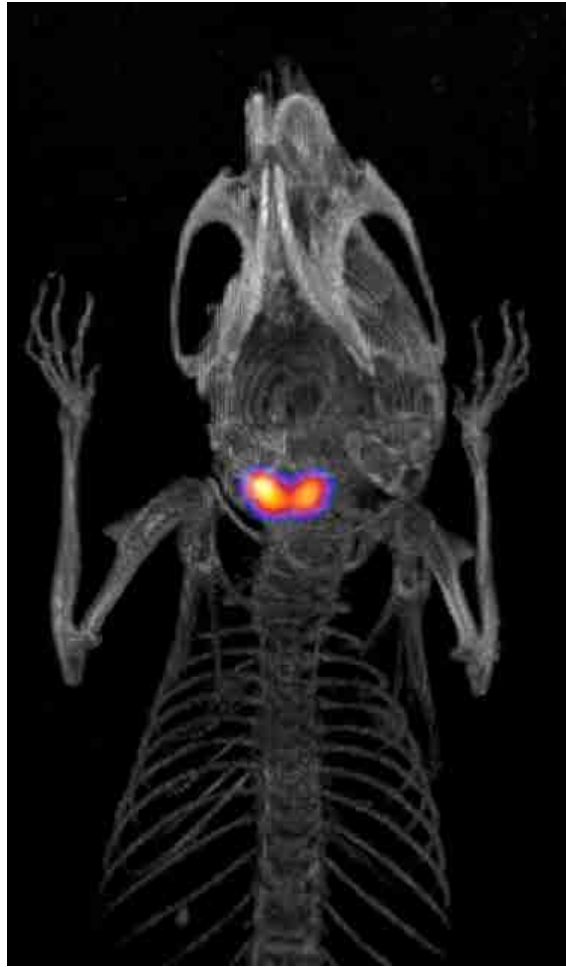

⑥

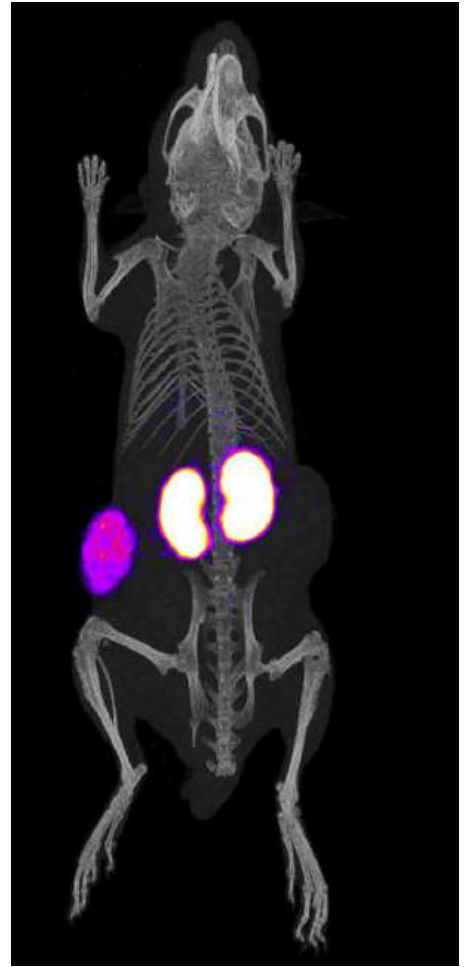

What makes MOLECUBES stand out?



Fast workflow

Thanks to our fast and simple CUBEFLOW and intuitive user interfaces, 3D images are obtained using a turnkey solution.



Modular

Our CUBES are designed to work both as stand-alone units and in modular combinations so you can optimize your workflow and build and scale at your own pace.



Benchtop

MOLECUBES offers exquisite whole-body mouse and rat imaging while fitting on top of any standard lab bench.



User friendly

Developed by end users, our systems aim at excellent image quality as well as a functional design and intuitive software to provide a high-throughput



High precision

Extremely high-quality imaging in terms of both resolution and precision and field of view at the smallest footprint.



Best uptime

98,6% System uptime and a dedicated support team with extensive preclinical imaging expertise.



MEET THE TEAM

Our team, with its roots in scientific research, combines more than 20 years of experience in hardware and software development. The R&D team is completed by a sales, applications and management team with a long track record in the preclinical area. We are one call away from helping you out.



GET IN TOUCH

MOLECUBES NV
Suzanne Tassierstraat 1 - 9052 Ghent
info@molecubes.com





MOLECUBES

"All information, images, logos, specifications, values, etc. are supplied without any obligation of Molecubes NV. Molecubes gives no guarantee concerning the usability, the correctness or the completeness of the information for a specific purpose. Nothing in this document can be interpreted as giving an explicit or tacit license to use Molecubes' intellectual property. © 2016 Molecubes NV. All rights reserved."



Flanders
State of the Art