



EVOQ® GC-TQ Speed

- More Speed Plus More Sensitivity
Speed To Results

EVOQ GC-TQ Speed

Speed Empowers Sensitivity for Residues and Contaminants



Using the fastest performing GC-TQ system facilitates rapid and accurate screening of samples ensuring labs keep pace with growing numbers of highly complex samples.

EVOQ GC-TQ Speed is the right solution to achieve greater insight into your samples. With extremely fast, selective, and sensitive data acquisition for quantitative and qualitative information your laboratory will perform at a whole new level from method setup to the data

evaluation and instrument maintenance. The rigorously designed system includes lens-free ion optics and a 180° curved collision cell that eliminates interferences of co-eluting compounds and neutrals, minimizes the need of maintenance, and maximizes the ease of use.



More Flexibility

Multiple autosampler options possible, from routine analysis to high throughput.

Improved Robustness

Lens-free design, curved ion path, and a large volume ion source all lead to less maintenance and higher productivity.

Increased Sensitivity

With effective noise canceling, analyte sensitivity is increased even for analytes in complex high-level matrices.

Faster Scanning

Allows shorter run times or more MRM transitions, without compromising sensitivity or ion ratio aspects.

Unrivaled GC-MS Performance



Speed combined with versatility



Productivity

- Increased speed to process more analytes and more samples
- Double filament ion source provides reliable signal with very low maintenance for higher uptime



Sensitivity

- Multi-axis (360°) noise cancelling on ion path
- Efficient ion transmission in the lens-free design
- Active helium focusing in the heated ion guide



Ease of Use

- CBS (Compound Base Scanning) for auto-fill of scantimes for optimized MRM transitions
- Simplified method setup with the lens-free ion optical path



Robustness

- High capacity turbo-pump standard provides reliable performance
- Heated ion guide prevents ion condensation
- Ultra-inert materials in the ion source reduces the need for cleaning



Reproducibility

- Highly robust ion source minimizes contamination and negative charging effects
- Reproducible fragmentation provides ion ratio precision



Even after four decades, GC-MS/MS continues to improve. EVOQ GC-TQ Speed is a breakthrough for faster analysis that sustains sensitivity and robustness.

Speed To Accurate Results

The patented lens-free design in the ion optical path simplifies the tuning process and the method setup for ease of use and minimizes the contamination for low maintenance.

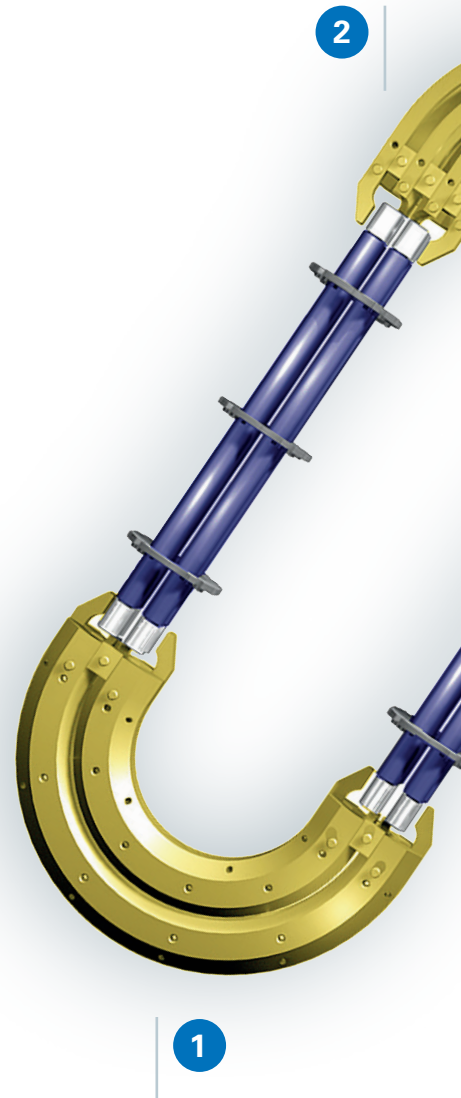

GC-MS/MS is no longer about specifications, but about solution performance, especially in difficult matrices.

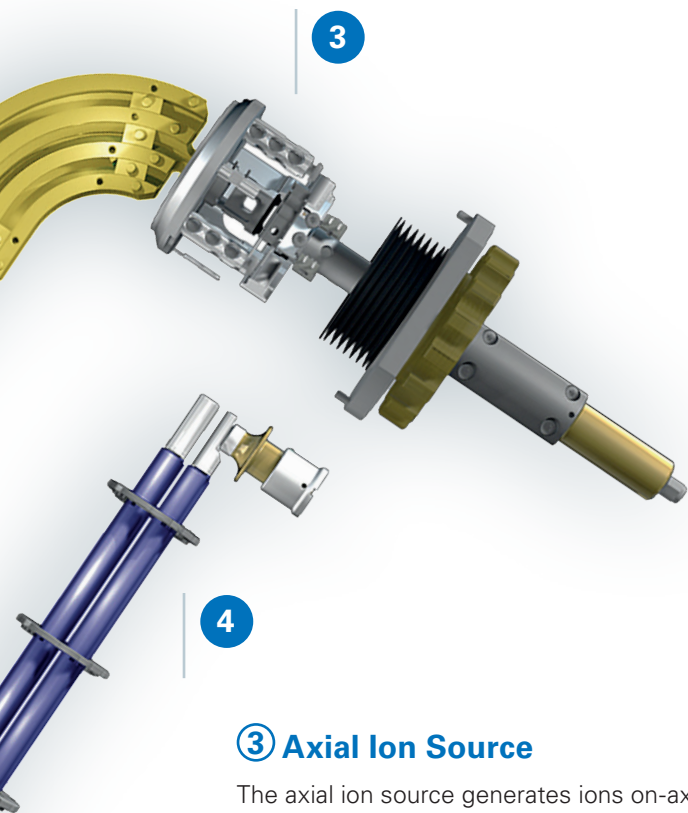

① 180° Curved Collision Cell

The unrivaled design of the collision cell produces clear information for the identification and quantitation of even trace-level compounds. The fast moving ions coming from the first quadrupole collide with the collision gas (usually argon) and get dissociated while interfering neutrals are removed in the 180° curved collision cell. This reduces the background noise and increases the signal-to-noise ratio, efficiently boosting MRM sensitivity in real sample matrix.

② Active Focusing Ion Guide

The unique ion-path and curved collision cell design results in virtually zero neutral ions or chemical noise reaching the detector. The ion guide is also heated to prevent the ions from condensing and contaminating the guide keeping the system clean and running at top performance. Active focusing uses helium molecules to concentrate the ion current and increase ion transmission to maximize sensitivity.

③ Axial Ion Source

The axial ion source generates ions on-axis from the GC column. Its unique inert lens design reduces contamination from the sample matrix for increased sensitivity. With double filaments and electron-bouncing technology, reliable ionization is achieved with less maintenance, higher uptime, and greater productivity.

④ EDR (Extended Dynamic Range) Detection

Extended Dynamic Range (EDR) automatically adjusts the detector for the best signal-to-noise ratio (S/N) and optimizes electron multiplier (EM) voltage for every scan.

When injecting large quantities of compounds, the detector may become "overloaded" resulting in poor linearity as the dynamic range of the instrument is not reached. The EDR allows a wider dynamic range for real samples where the amount of analyte present is unpredictable.

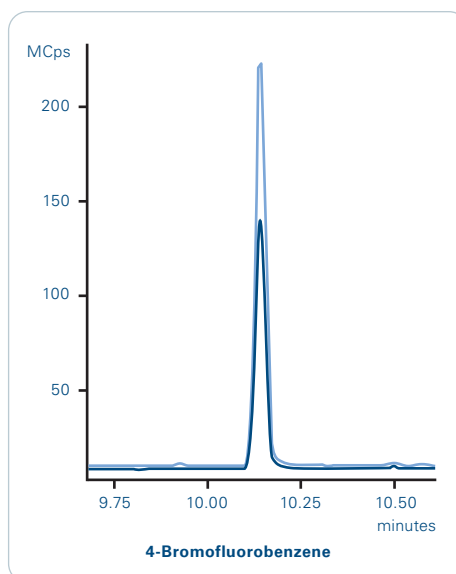

Effect of the active focusing ion guide (see 2). Analysis of 4-Bromofluorobenzene; light blue: Helium on, dark blue: Helium off.

Speed to Solutions in Environmental Analyses

Every chromatographer knows that it's not just about the speed of the analytical system and shorter run times. Sample preparation is the key to a robust, sensitive and rapid method. Together with the high scanning speed and stable sensitivity, Bruker has developed a fast and easy-to-use sample preparation for water analysis.

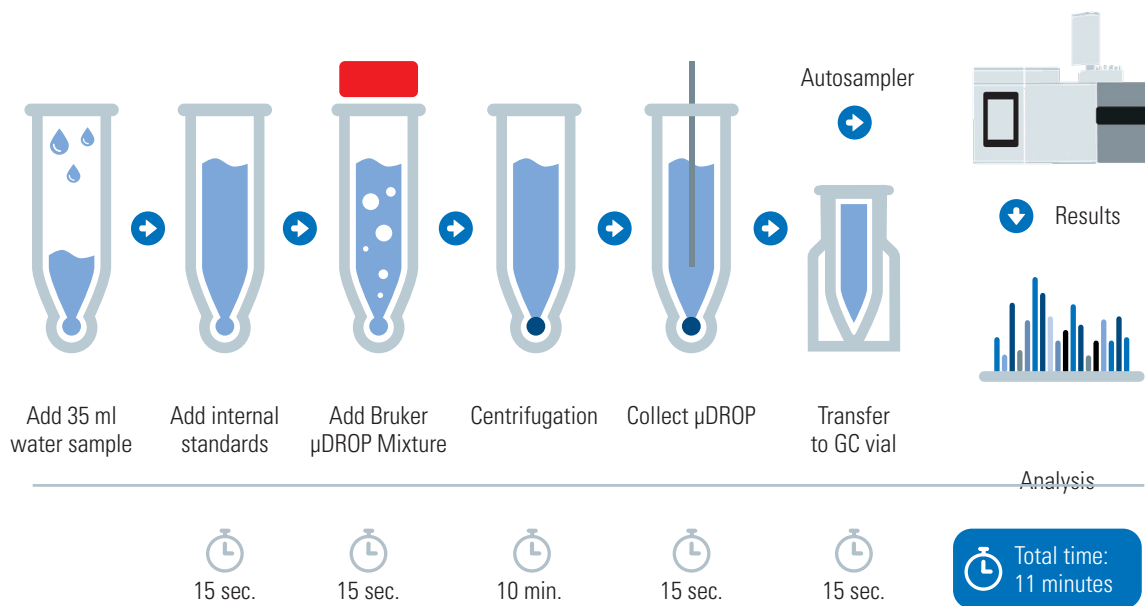

μ DROP sample preparation and the fast scanning possibilities of Bruker's GC-MS system:

- Reduces the cost per sample by a factor of 20 and more due to the very limited use of solvents and consumables
- Dramatically decreases the time from sample to report in comparison to other techniques
- Leads to faster turn-around-time

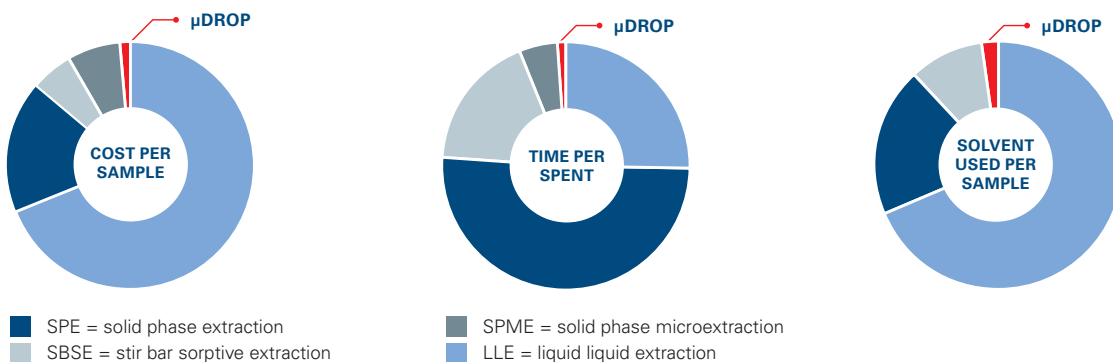

Speed To Results in Dioxin Analysis

Dioxin analysis is challenging. Previously, this analysis was only certified on large magnetic sector mass spectrometers. This is due to the fact that the ion ratios must be stable for a correct determination of the different components. The EVOQ® GC-TQ Speed has excellent ion ratio stability, which is maintained even at high scan speeds.

This enables a fast screening process and increased throughput. This increased productivity has a positive effect on the price per sample. In addition, for dioxin analysis, the cost per sample is largely determined by sample preparation and run times; the impact of the instrument on the cost per sample is mostly dependent on system robustness and reliability. Robustness is a key advantage of the EVOQ GC-TQ Speed.

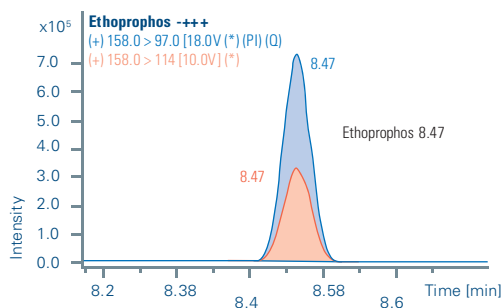

Regular method: Ethoprophos scan time 167 ms

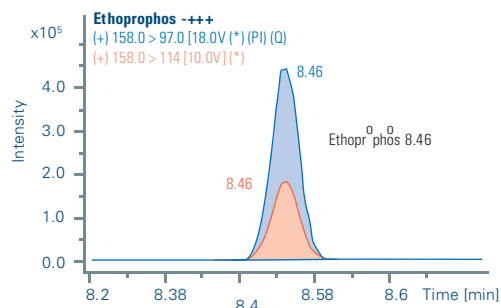

Speed method: Ethoprophos scan time 4 ms

Ion ratio is a critical parameter for conformation and identification in MRM method setup. Typically faster scanning will influence the ion ratio and will create an increased number of false positive and false negative identifications. EVOQ GC-TQ Speed is able to maintain the ion ratio even with a 40 times faster scan rate. This is valuable for both pesticide and dioxin analysis.

Speed Through Method Development

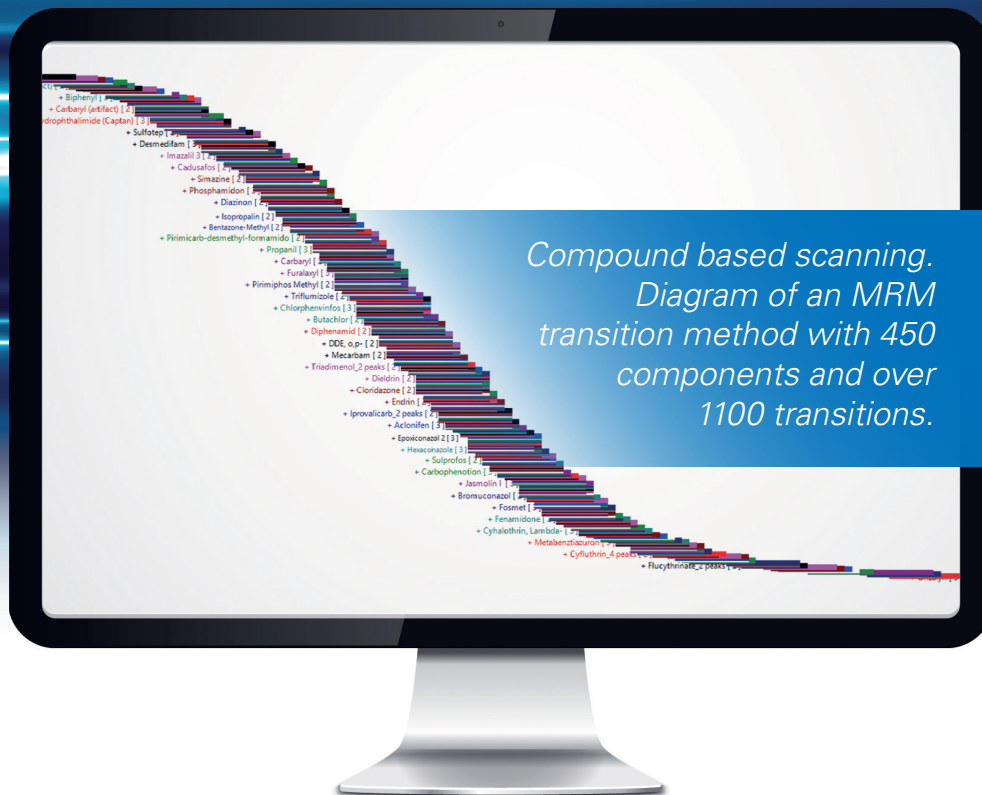

The Compound Based Scanning (CBS) software function automatically calculates the scan time for each compound in dynamic windows. The unique MRM builder makes creating a method faster and easier than ever before.

MRM Method Builder feature in tqControl software makes short work of method generation for a long list of analytes on the EVOQ® GC-TQ Speed. Users have two options: either insert the analyte from the MRM library or use the MRM builder which optimizes the analyte for you. A simple drag-and-drop of the compound from the factory-installed compound library, which contains more than 3000 MRM transitions, automatically sets up the method and manages the TQ duty cycle.

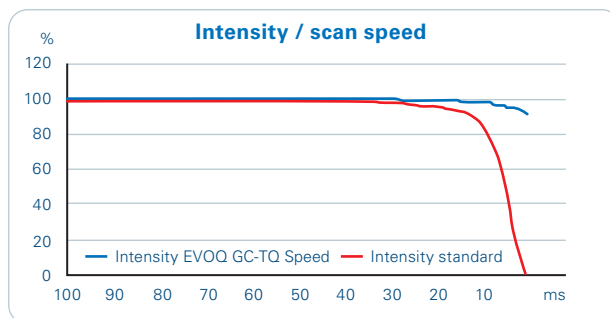

The fast-scanning capability of the EVOQ GC-TQ Speed allows multiple transitions for each compound to be optimally monitored during a single analytical run. By maintaining the individual retention time window of each compound, the number of simultaneous transitions is reduced, resulting in the most efficient duty cycle, thereby increasing the sensitivity of the test.

Reliable Results with Superb Software

Simple, Intuitive, Powerful

To obtain accurate sample results, every laboratory around the world needs clear automated reports with unambiguous results. Unfortunately, some very difficult matrices can present additional challenges. To overcome these, improvements in peak picking and computational performance ensure that the highest levels of robustness and accuracy are maintained. Superior hardware linked to specialized software guarantees excellent results.

Bruker's Targeted Analysis for Screening and Quantification (TASQ) software was specially developed for automatic reports and is incorporated smoothly into tqControl. The goal of TASQ is to minimize false-positive or false-negative identifications, provide highly accurate quantitative results, and enable easy data review of components.

After all, the software you use every day should make your life easier, and that's the real function of TASQ. Blue ribbon icons that appear during the workflow show at a glance at which point of data processing you are currently working.

The tqControl approach has focused on QC and targeted screening. The software is designed to streamline and speed up workflows and provide automation wherever possible by using scoring rules for common routine parameters. Critical to the ease of data review and ultimate quality of the data analysis, it indicates with a flag when doubts arise about the validity of the result. All reports can be exported to LIMS in a flexible setup.

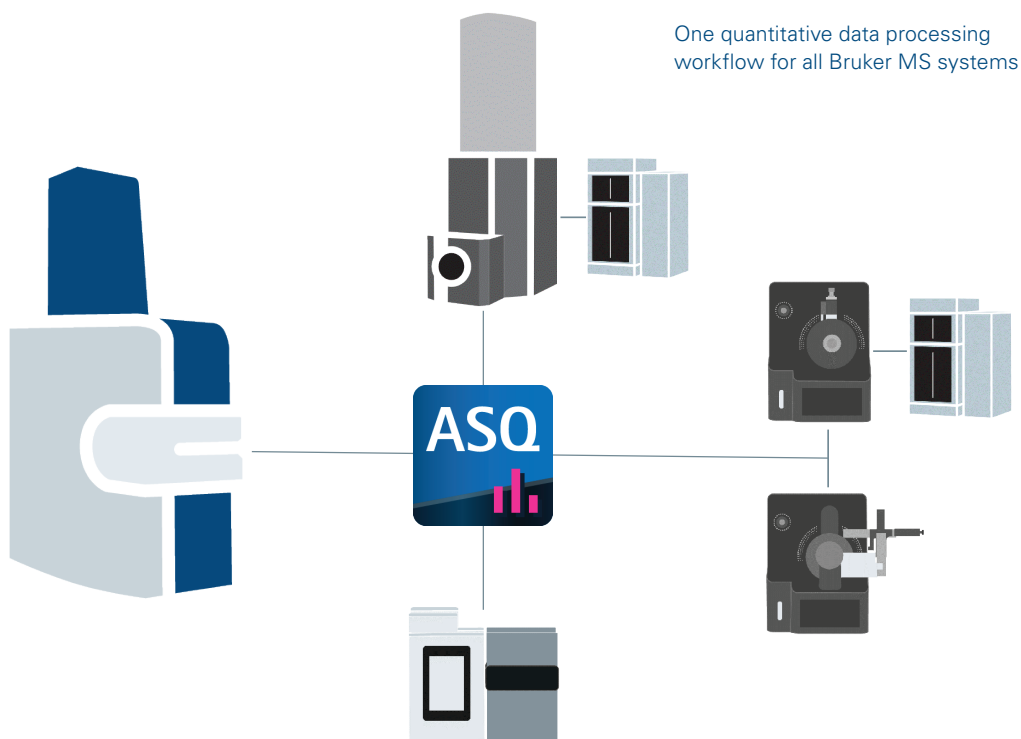

Gas Chromatographs and Hardware Options

An Infusion of Innovation with a Legacy of Reliability

The GC is the key part to the reliability, robustness, and sensitivity of any GC-MS analysis. Bruker's philosophy of innovation is highlighted by the choice of two GCs built to support the ultra-sensitive EVOQ® GC-TQ Speed. The compact 8300 GC and the larger, more versatile 8500 GC can accommodate two columns in the oven. Both are available with the new backflush technology. The GCs are also equipped with a multilanguage touchpad display supporting 13 languages.

8300 GC

Compact design for those focused on routine applications requiring maximum throughput using one or two injectors.

- Select up to 2 injectors: Split/Splitless (SSL), Programmable Temperature Vaporization (PTV)
- Support of a GC detector and the mass spectrometer
- High precision electronic pressure control
- 9 temperature controlled zones up to 450 °C

8500 GC

Versatile design with additional injector and detector options for laboratories seeking multipurpose analysis using both GC and GC-MS.

- Select up to 3 injectors: SSL, PTV
- Add up to 3 GC detectors: FID, ECD, TCD, PFPD
- High precision electronic pressure control
- All temperature zones up to 450 °C



EVOQ GC-TQ Speed
with 8500 GC and
8400 Pro autosampler



EVOQ GC-TQ Speed
with 8500 GC and
CTC PAL3 autosampler



EVOQ GC-TQ Speed
with 8300 GC and
8400 Pro autosampler

The EVOQ[®] GC-TQ Speed Sets a New Industry Standard for GC-MS

All over the world many people and laboratories are working to get our world cleaner and healthier. To achieve this, they need to detect lower levels and measure more samples than ever before. This requires hassle-free, easy-to-use tools with out-of-the-box solutions that enable accurate and fast reporting. EVOQ[®] GC-TQ Speed was developed with precisely this aim. For easy review and reporting the software has standard client/server capabilities.

Please contact us.

OFN speed versus sensitivity

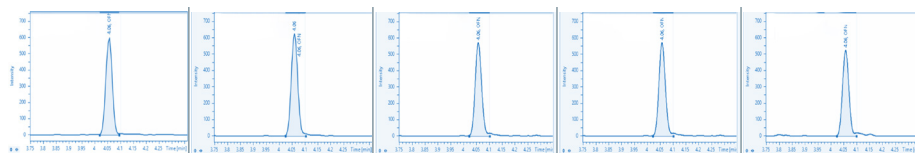

Scan Time (ms)	333	100	10	4	1
Peak Area	965	1013	943	1002	916
%RSD (n=6)	5.04%	4.09%	1.78%	3.20%	3.68%

What are the most important needs of a GC-MS triple quadrupole system in a laboratory?

- ✔ Excellent sensitivity in matrix
- ✔ Robust sustainable performance within matrix
- ✔ Fast results of real samples
- ✔ Easy to use software

Standard specification of “artificial” examples without matrix will not give you an answer. Due to the source design of Bruker's GC-MS, the larger ion volume, and the avoidance of areas where matrix disposition can occur, optimal performance is guaranteed even when a complex matrix is in your sample. Are you curious about the ease-of-use and the performance of the EVOQ GC-TQ Speed, please contact your local Bruker representative.

EVOQ[®] GC-TQ Speed

More Speed Plus More Sensitivity
Speed To Results



Robust maintenance free • Increased speed without losing sensitivity
• Best ion ratio stability available

- 30,000 Da/sec
- Higher throughput enabled by high scan speed
- 1000 MRM/s
- Digital electronics coupled to a fast scanning detector preserve high-sensitivity during high-speed data acquisition

For Research Use Only. Not for use in clinical diagnostic procedures.

● **Bruker Daltonik GmbH & Co. KG**

Bremen · Germany

Phone +49 (0)421-2205-0

Bruker Scientific LLC

Billerica, MA · USA

Phone +1 (978) 663-3660



**Scan the QR-Code
for more Details**

ms.sales.bdal@bruker.com - www.bruker.com